



Jun/26



## SHOTGUN - STAGE 1

Targets (type & number)	7 Poppers, 9 IPSC Metal Plates, 2 Noshoots
Minimum number of rounds	16
Ammo	Bird
The shotgun ready condition	Loaded (Option one) as per rule 8.1.1.1
Competitor Ready Condition	Standing erect with the shotgun in the ready condition held in both hands, stock touching the competitor at hip level, trigger guard downwards, muzzle pointing downrange and with the fingers outside the trigger guard, Standing anywhere into demarcated area as demonstrated
Time starts: audible or visual signal	Audible
Procedure	After the signal shoot at the targets

### Stage 1 – Take Down

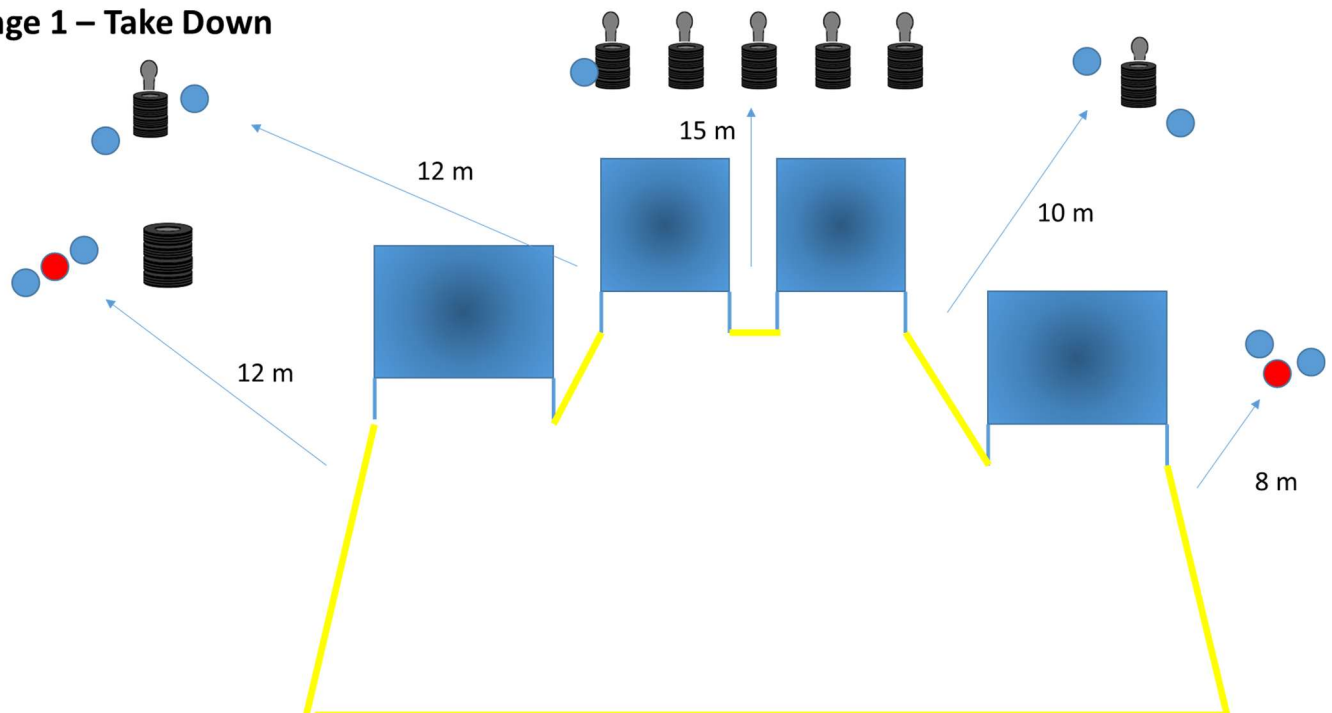



Jun/26



## SHOTGUN - STAGE 2

Targets (type & number)	14 IPSC Metal Plates + 2 Poppers
Minimum number of rounds	16
Ammo	Bird
The shotgun ready condition	Loaded (Option one) as per rule 8.1.1.1
Competitor Ready Condition	Standing erect with the shotgun in the ready condition held in both hands, stock touching the competitor at hip level, trigger guard downwards, muzzle pointing downrange and with the fingers outside the trigger guard, Standing anywhere into demarcated area as demonstrated
Time starts audible or visual signal	Audible
Procedure	After the signal shoot at the targets, P1 starts the mobile, remains visible at rest.

### Stage 2– Windows

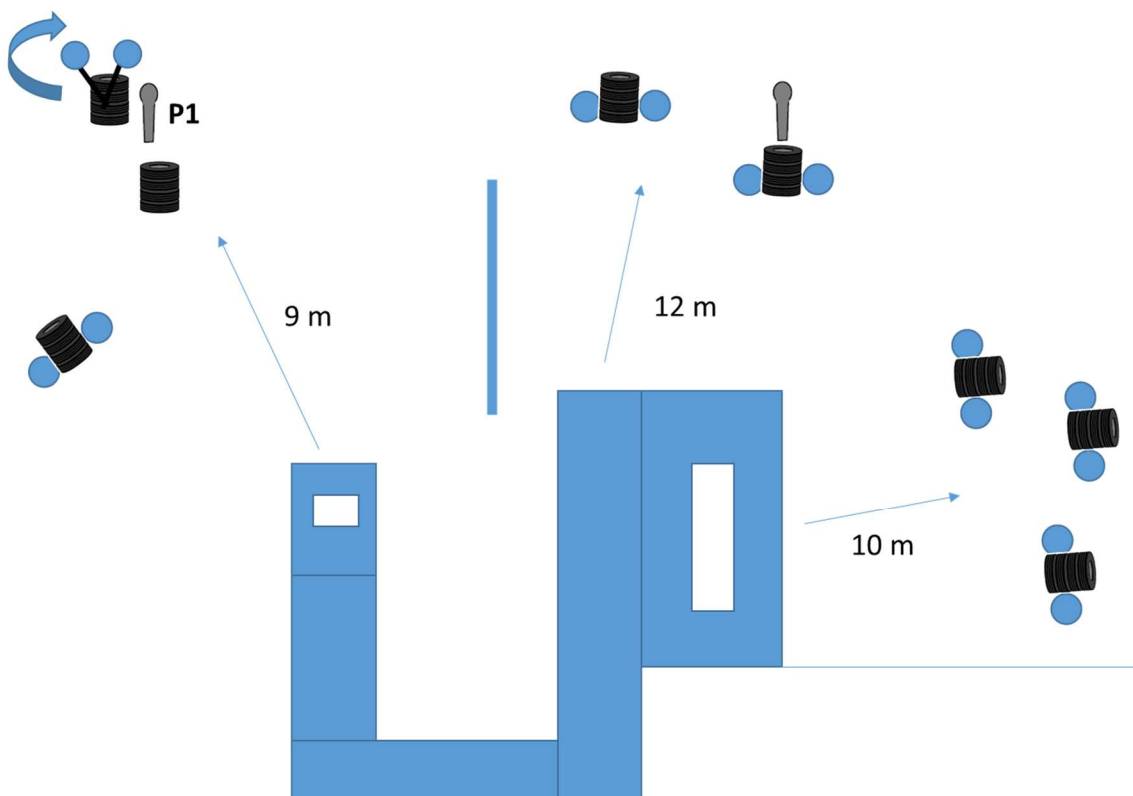



Jun/26



### SHOTGUN - STAGE 3

Targets (type & number)	16 IPSC Metal Plates, 1 noshoot
Minimum number of rounds	16
Ammo	Bird
The shotgun ready condition	Loaded (Option 1) as per rule 8.1.1.1
Competitor Ready Condition	Standing erect with the shotgun in the ready condition held in both hands, stock touching the competitor at hip level, trigger guard downwards, muzzle pointing downrange and with the fingers outside the trigger guard, Standing anywhere into demarcated area as demonstrated
Time starts: audible or visual signal	Audible
Procedure	After the signal shoot at the targets

#### Stage 3 – Flying – 16 Rounds

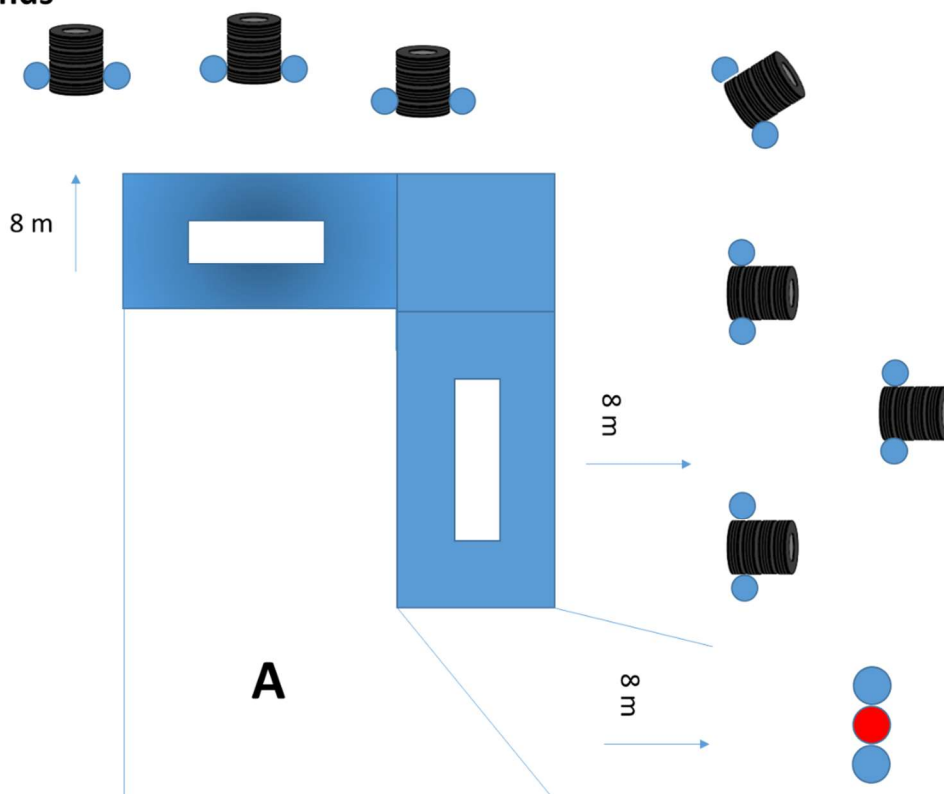



Jun/26



## SHOTGUN - STAGE 4

Targets (type & number)	28 IPSC Metal Plates, 1 No Shoots
Minimum number of rounds	28
Ammo	Bird
The shotgun ready condition	Loaded (Option one) as per rule 8.1.1.1
Competitor Ready Condition	Standing erect with the shotgun in the ready condition held in both hands, stock touching the competitor at hip level, trigger guard downwards, muzzle pointing downrange and with the fingers outside the trigger guard, Standing anywhere into demarcated area as demonstrated
Time starts audible or visual signal	Audible
Procedure	After the signal shoot at the targets

### Stage 4 – Zig Zag – 28 Rounds

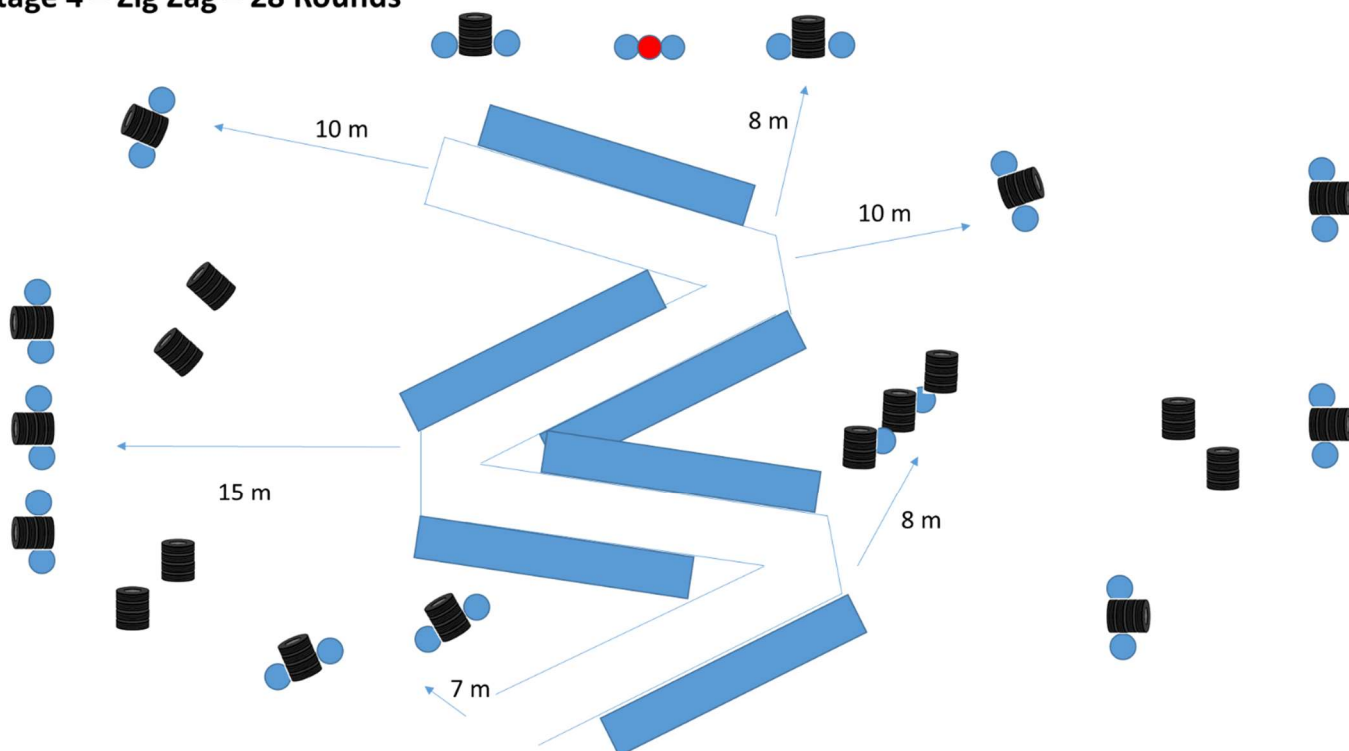



Jun/26



## SHOTGUN - STAGE 5

Targets (type & number)	8 IPSC Metal Plates
Minimum number of rounds	8
Ammo	Bird
The shotgun ready condition	Unloaded (Option three) as per rule 8.1.1.3
Competitor Ready Condition	Gun on the table, shells and magazines in another table inside the bow as demonstrated
Time starts: audible or visual signal	Audible
Procedure	Gun must to be at the mark on the table (A or B), shells and or magazines must to be inside the bow in other table, shooter touching the start line with foot. After the signal shoot at the targets

### Stage 5 – Triangle

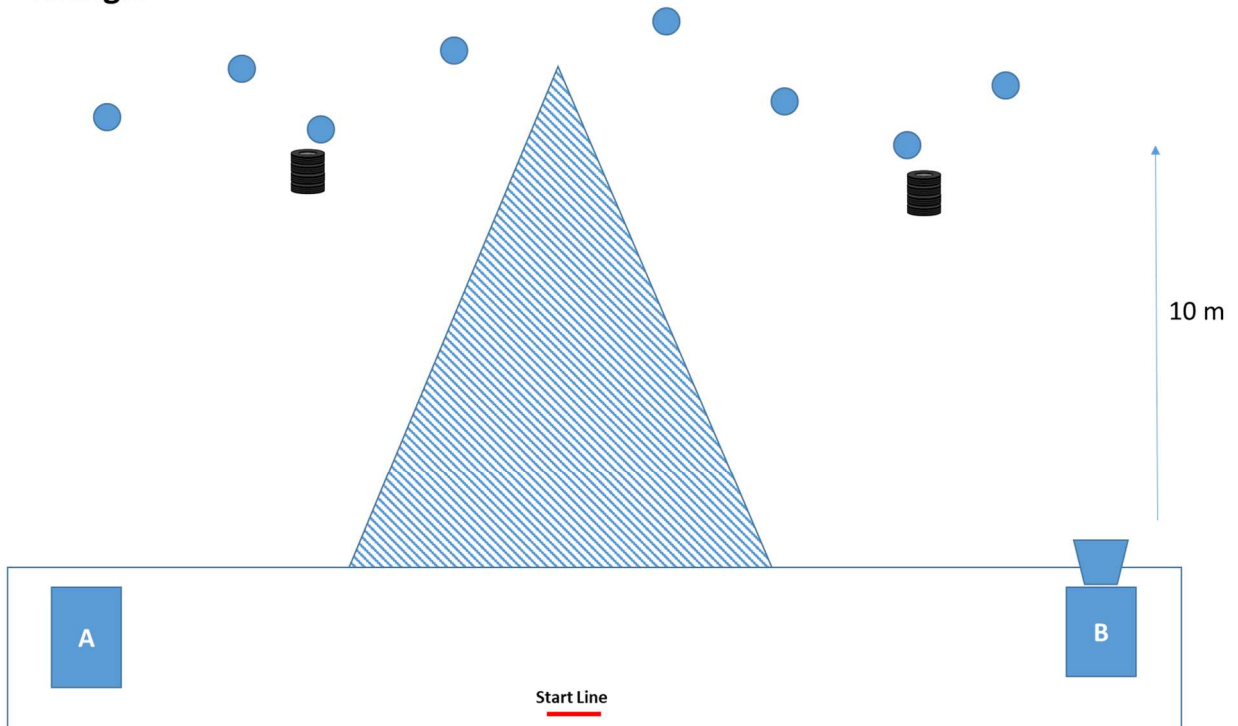



Jun/26



## SHOTGUN - STAGE 6

Targets (type & number)	6 Poppers, 2 IPSC Metal Plates
Minimum number of rounds	8
Ammo	Bird
The shotgun ready condition	Unload (Option three) as per rule 8.1.1.3
Competitor Ready Condition	Standing erect with the shotgun in the ready condition held in weak hand, stock touching the competitor at hip level, trigger guard downwards, muzzle pointing downrange and with the fingers outside the trigger guard, Standing anywhere into demarcated area as demonstrated
Time starts: audible or visual signal	Audible
Procedure	After the signal shoot at the targets, P1 starts mobile and remains visible at rest

### Stage 6 – Swingers – 8 Rounds

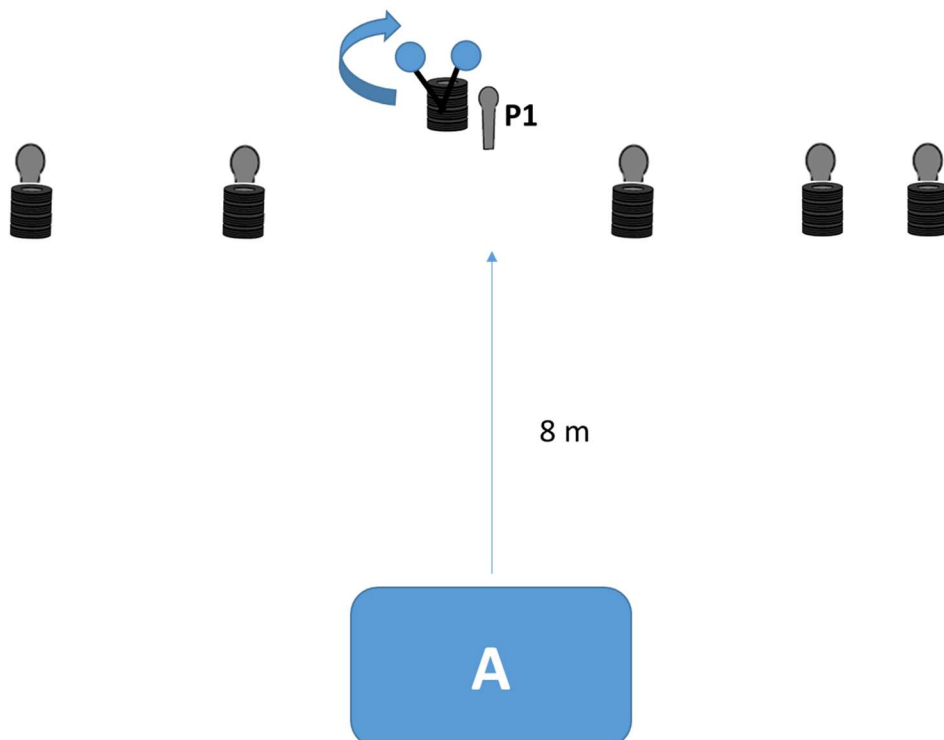



Jun/26



## SHOTGUN - STAGE 7

Targets (type & number)	7 IPSC Metal Plates + 1 Popper
Minimum number of rounds	8
Ammo	Bird
The shotgun ready condition	Loaded with chamber empty (Option two) as per rule 8.1.1.2
Competitor Ready Condition	Standing erect with the shotgun in the ready condition held in both hands, stock touching the competitor at hip level, trigger guard downwards, muzzle pointing downrange and with the fingers outside the trigger guard, Standing anywhere into demarcated area as demonstrated
Time starts: audible or visual signal	Audible
Procedure	After the signal shoot at the targets

### Stage 7 – Corner

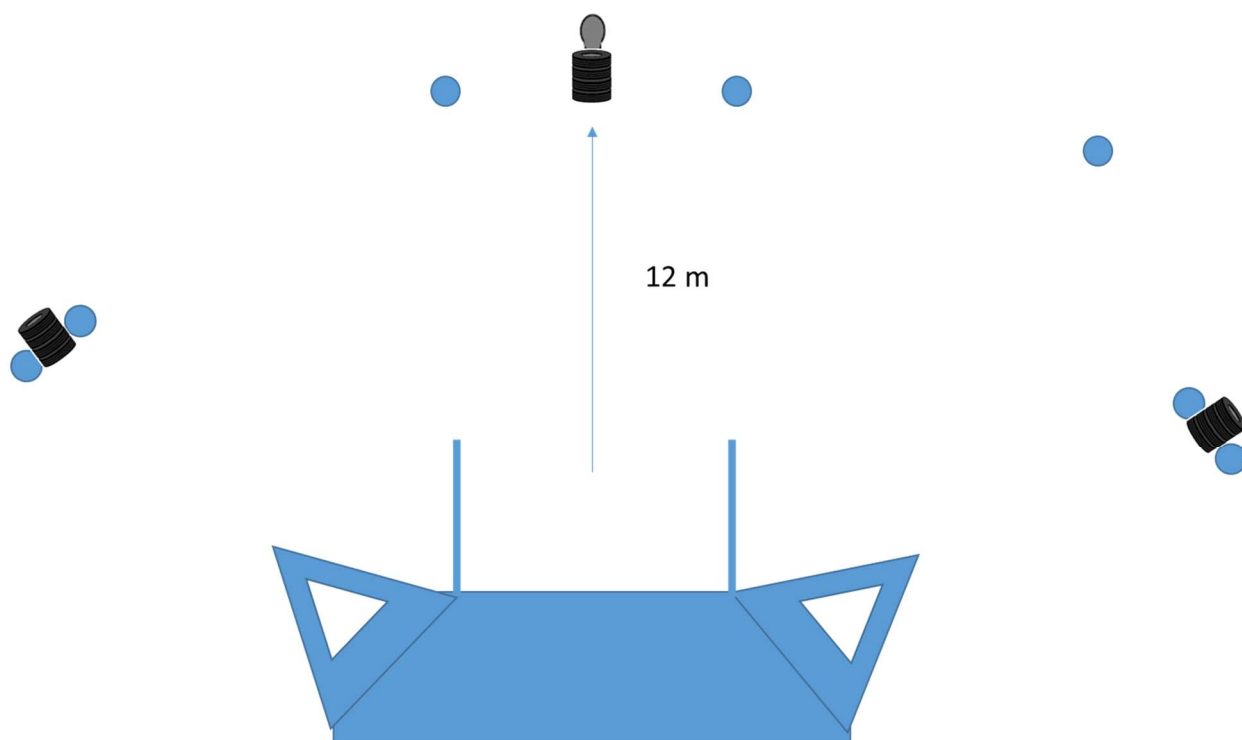



Jun/26



## SHOTGUN - STAGE 8

Targets (type & number)	8 IPSC Metal Plates, 8 Noshoots
Minimum number of rounds	8
Ammo	Bird
The shotgun ready condition	Loaded (Option one) as per rule 8.1.1.1
Competitor Ready Condition	Standing erect with the shotgun in the ready condition held naturally in the strong hand only, barrel parallel to the ground, trigger guard downwards, muzzle pointing downrange with fingers outside the trigger guard and weak hand hanging naturally at the side., Standing anywhere into demarcated area as demonstrated
Time starts: audible or visual signal	Audible
Procedure	After the signal shoot at the targets,

### Stage 8– Be careful

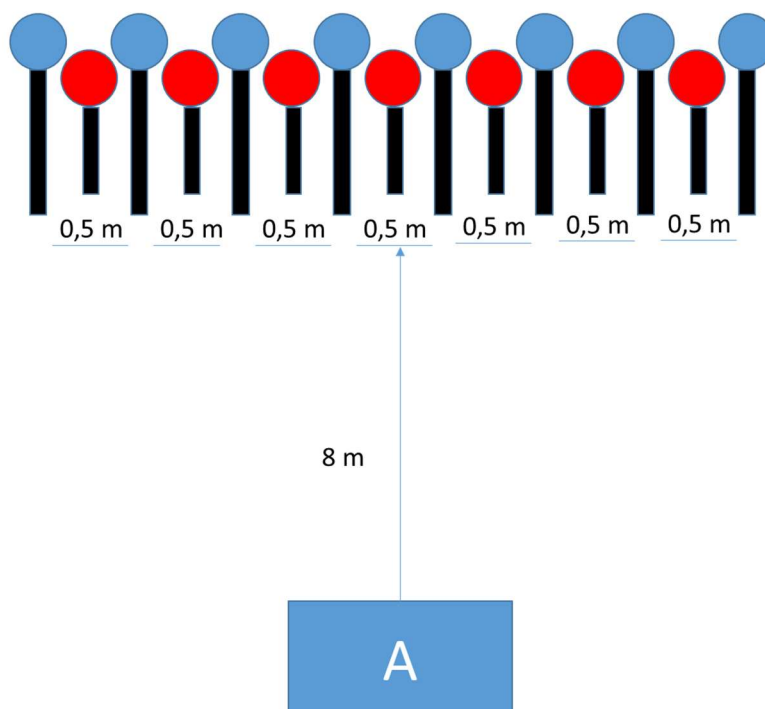



Jun/26



## SHOTGUN - STAGE 9

Targets (type & number)	5 IPSC Classic Targets, 1 No Shoots
Minimum number of rounds	5
Ammo	Slug
The shotgun ready condition	Loaded (Option one) as per rule 8.1.1.1
Competitor Ready Condition	Standing erect with the shotgun in the ready condition held in both hands, stock touching the competitor at hip level, trigger guard downwards, muzzle pointing downrange and with the fingers outside the trigger guard, Standing anywhere into demarcated area as demonstrated
Time starts: audible or visual signal	Audible
Procedure	After the signal shoot at the targets

### Stage 9 – Slugger

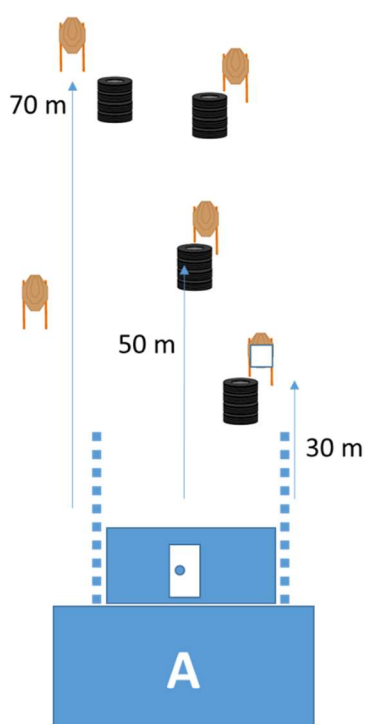



Jun/26



## SHOTGUN - STAGE 10

Targets (type & number)	16 IPSC Metal Plates,
Minimum number of rounds	16
Ammo	Bird
The shotgun ready condition	Loaded (Option 1) as per rule 8.1.1.1
Competitor Ready Condition	Standing erect with the shotgun in the ready condition held in both hands, stock touching the competitor at hip level, trigger guard downwards, muzzle pointing downrange and with the fingers outside the trigger guard, Standing anywhere into demarcated area as demonstrated
Time starts: audible or visual signal	Audible
Procedure	After the signal shoot at the targets

### Stage 10– Be fast

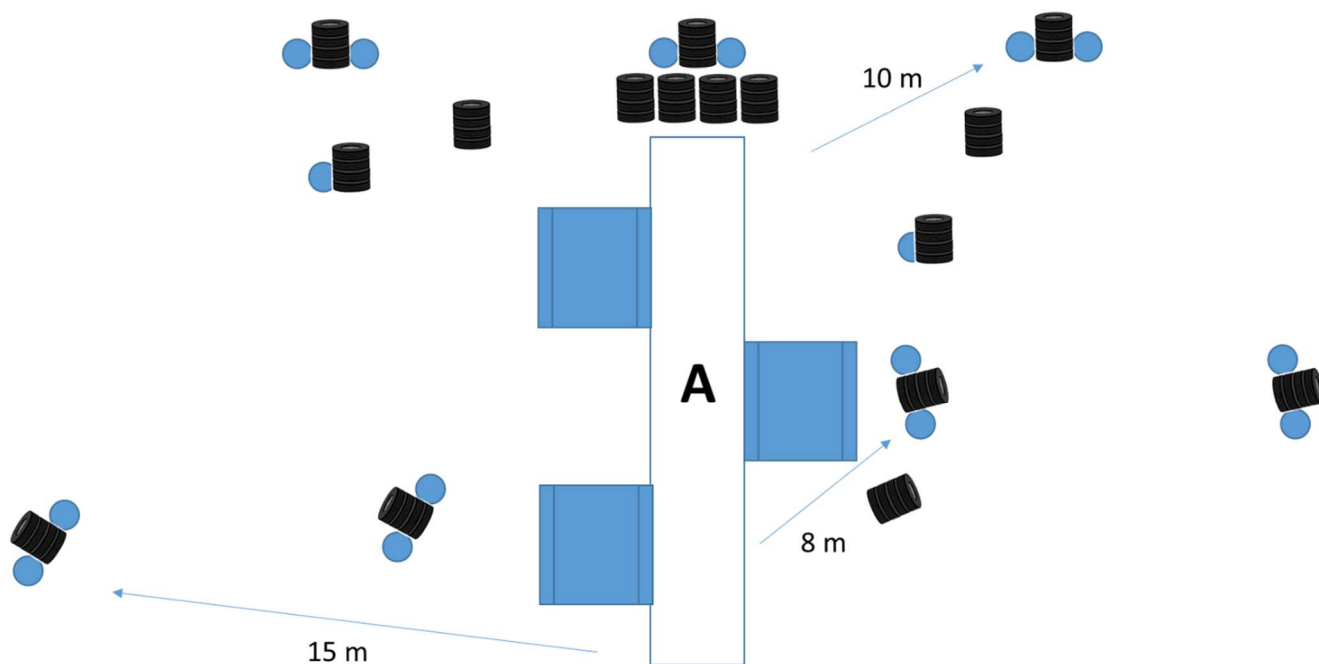



Jun/26



## SHOTGUN - STAGE 11

Targets (type & number)	26 IPSC Metal Plates, 2 Poppers
Minimum number of rounds	28
Ammo	Bird
The shotgun ready condition	Loaded (Option one) as per rule 8.1.1.1
Competitor Ready Condition	Standing erect with the shotgun in the ready condition held in both hands, stock touching the competitor at hip level, trigger guard downwards, muzzle pointing downrange and with the fingers outside the trigger guard, Standing anywhere into demarcated area as demonstrated
Time starts: audible or visual signal	Audible
Procedure	After the signal shoot at the targets

### Stage 11 – too long

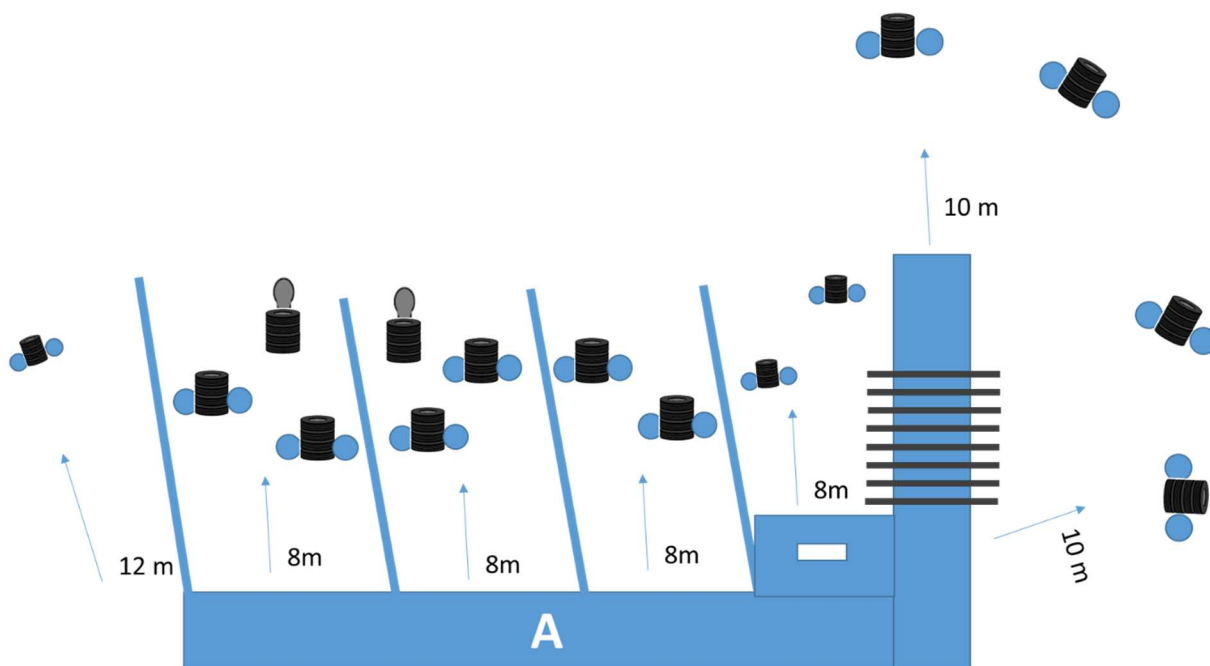



Jun/26



## SHOTGUN - STAGE 12

Targets (type & number)	4 IPSC A4 targets, 2 IPSC metal plates
Minimum number of rounds	6
Ammo	Buckshot
The shotgun ready condition	Loaded (Option one) as per rule 8.1.1.1
Competitor Ready Condition	Standing erect with the shotgun in the ready condition held in both hands, stock touching the competitor at hip level, trigger guard downwards, muzzle pointing downrange and with the fingers outside the trigger guard, Standing anywhere into demarcated area as demonstrated
Time starts: audible or visual signal	Audible
Procedure	After the signal shoot at the targets

### Stage 12 – Buck Only

